



Evaporator **IW-2**

The IW-2 is designed to free up the overhead compartment where traditional evaporators are located. The IW-2 evaporator can also be matched with other MCC components to

provide a complete air conditioning system that meets your exact vehicle size, operating mode, and climate.



Features

- Lightweight aluminum frame construction
- Flexible mounting configurations for every make or body
- Integrated motor cover panel for ease of service
- State-of-the-art enhanced coils for maximum cooling capacity
- Flush mount installation provides maximum head clearance and clean OEM appearance
- Easy access return air filter provides for reduced service time

Evaporator IW-2

MCC Evaporators

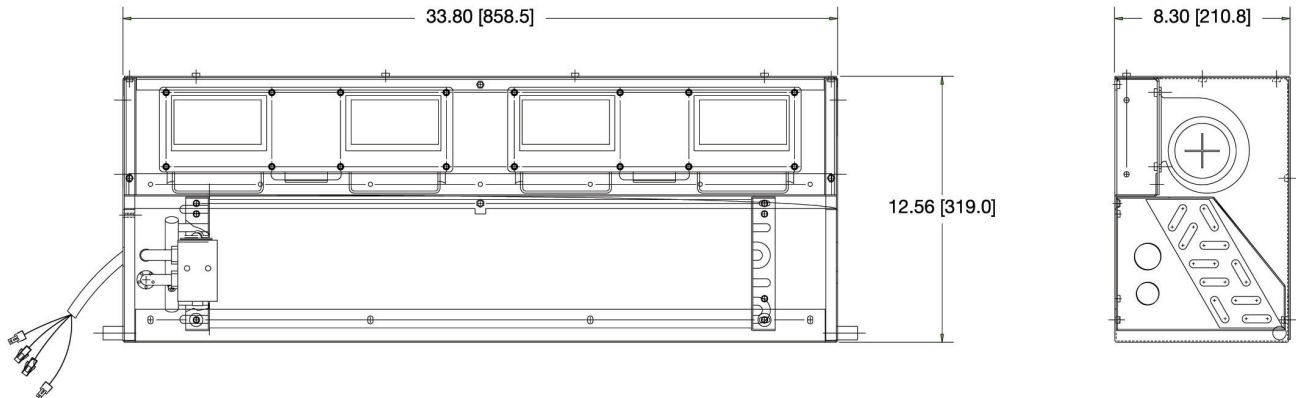

Technical Data

Cooling capacity	45000 Btu/hr (13.2 kW) IMACA ^[1]	18500 Btu/hr (5.42 kW) ARI ^[2]
Air flow	800 CFM (1359.2 m ³ /hr)	
Refrigerant	R134a	
Length	33.8" (858.5 mm)	
Width	8.30" (211 mm)	
Height	12.56" (319 mm)	
Weight	45 lbs (20.41 kg)	
Condensate drain connection	½" (12.7 mm) OD	
Max amperage requirement	23.7 A @ 13.5 V dc (High Speed)	
Voltage	12 or 24 VDC	
Cover color	Snow White or Dove Gray	

[1] IMACA conditions: 100°F (38°C) / 90°F (32°C) / 50% RH

[2] ARI conditions: 95°F (35°C) / 80°F (27°C) / 50% RH

