



## Compressor Valeo **TM-15**

# Heavy duty for Truck, Bus and Off Road equipment

The TM series compressors were designed to cover a wide range of applications, ideal for any customer requiring adaptation flexibility. The TM compressors incorporate the latest design improvements to better meet the needs of today's Heavy Duty systems.

The TM family boasts extends to:

- The drive end, through a wide range of interchangeable pulley profiles (A, B and PKP), pitch diameters and bi-directional clutch plates
- The refrigerant connections end through a range of back caps or a wide range of fittings that are pad-mounted to the back cap
- Two alternative mounting provisions: Ear or Direct



### Features

- Adaptable heavy duty compressors
- High efficiency and performance
- Lightweight and compact
- High reliability
- Low vibrations and noise

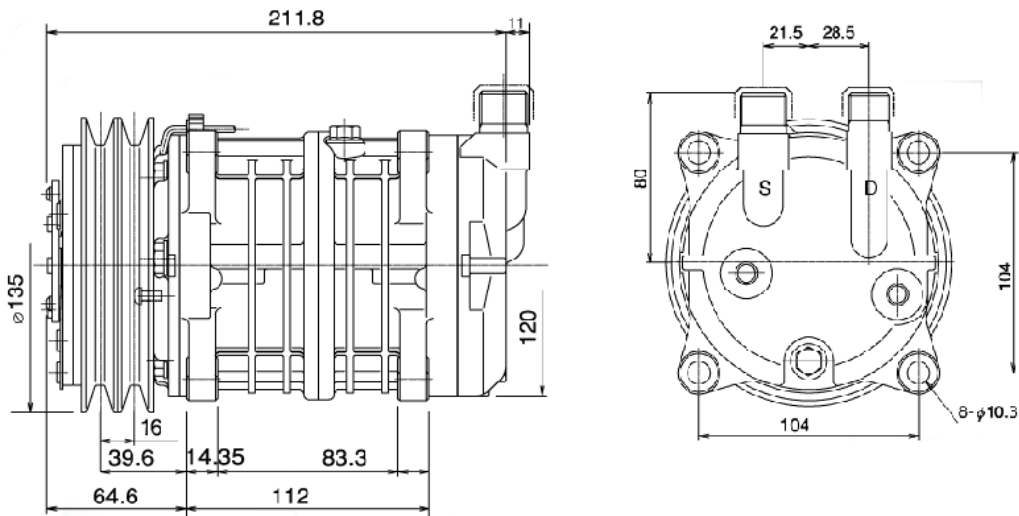

## Technical Data

Rotation	CW / CCW
Max speed	700 – 6000 rpm
Clutch coil	12 or 24 VDC
Displacement	9 in <sup>3</sup> (147 cm <sup>3</sup> )
Number of pistons	12 (6 x 2)
Refrigerant	R134a
Pulleys <sup>[1]</sup>	135-1AG 135-2AG 137-1bg 119 (4PK / 6PK / 8PK)
Mounting	Ear or Direct
Unloading steps	N/A
Oil charge	ZXL 100PG PAG OIL 5.3 oz (150 cm <sup>3</sup> )
Weight (without clutch)	10 lbs (4.6 kg)

[1] Outside diameters