



Electric Roof Mount HVAC **Eco 136e**

Electric parallel roof mount HVAC system

MCC's newest line member Eco 136e completes the portfolio of compact and super efficient roof mount HVAC systems designed to meet all OEM bus requirements. These HVAC systems offer very adaptable and flexible heating, ventilation and air conditioning solutions for best in class passenger comfort in transit, intercity buses, and coaches. The aluminum electric piston compressor integrated into the unit offers reduced weight, variable speed control, and cylinder unloading. The wide modulation range allows efficient power management

without having to cycle the compressor, providing optimal operation minimizing energy consumption. Noise, vibration, and harshness (NVH) reduction are achieved by using a quiet compressor, with special mount design and minimized compressor cycling. A higher capacity scroll compressor also available. A robust inverter, very efficient and reliable, drives the compressor. Air cooling of the inverter improves the overall reliability by reducing complexity. This unique advanced designed air-cooled inverter drives the compressor with fewer components resulting in greater reliability.



Features

Benefits

- Variable speed electric powered compressor
- Self contained, fully sealed, factory charged and tested
- Long life brushless fan motors
- Reliable CAN enabled microprocessor-based controls
- Heavy duty heat exchanger coils
- Easy access to internal parts and components
- Zero ozone depleting, high efficiency HFC R134a
- Advanced coil and airflow technology
- Compact design minimizing installation area
- EcoTemp MAX Controller

- Maximizes efficiency for providing output capacity to need
- Long life compressor
- No customer cost for equipment and time to connect and charge refrigerant
- Provides up to 40,000 hours life cycle along with high efficiency to minimize electrical power
- Communicates with vehicle electronics for optimized control and operation
- Long life durable to meet environmental conditions
- Saves time for seasonal maintenance or other service
- Friendly to the environment
- Provides 15% efficiency benefit versus competitors saving energy and operating cost
- Space saved can allow installation on hybrid and CNG buses
- Latest electronic design for optimized control
- OLED display provides outstanding display no matter from what angle or lighting conditions

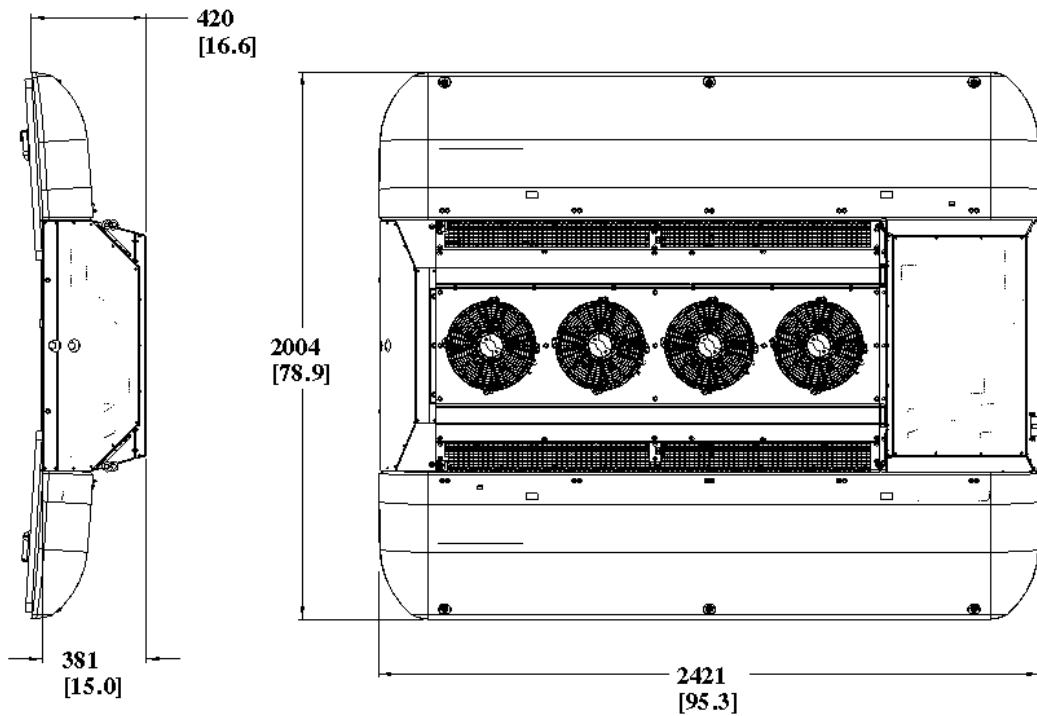

Technical Data

Refrigerant	R134a	
Cooling capacity @ max ^[1]	109000 Btu/hr (32kW)	
Cooling capacity @ ARI ^[2]	82000 Btu/hr (24 kW)	
Glycol Heating @ 7 gpm (100F Δ T)	130000 Btu/hr (38 kW)	
Electric Heating	54500 Btu/hr (16 kW)	
Evaporator air capacity	3900 CFM (6600 m ³ /hr)	
Length	96" (2430 mm)	
Width	79-86" (2010 - 2180 mm)	
Height	15" (380 mm) max (at the compressor enclosure)	
Weight	660 lbs (300 kg)	
Low voltage power consumption	100 A @ 26 VDC	
High voltage power consumption ^[3]	20 A @ 650 VDC or 480 VAC 3-PH	40 A @ 330 VDC or 240 VAC 3-PH
OPTION: Refrigerant to glycol chiller	12000 Btu/hr (3.5 kW)	

[1] Max conditions 95°F (35°C)/104°F (40°C)/50% RH
 [2] ARI conditions: 95°F (35°C) / 80°F (27°C) / 50% RH
 [3] Nominal w/o electric heat

