

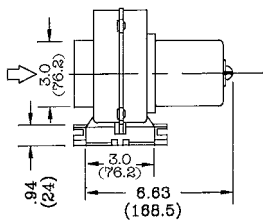

# XII. Blowers

# Blower Model 503

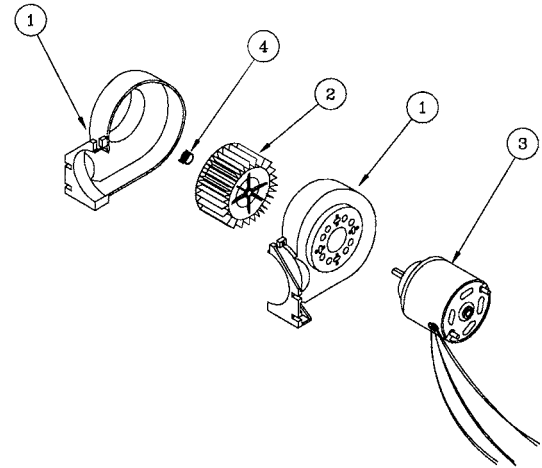
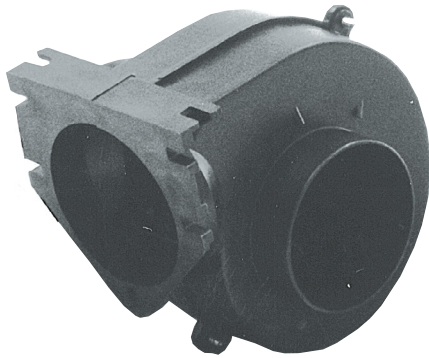

EL. leads, Ext. 20"±2" (500±50)  
 Orange -High speed  
 Red -Low speed  
 Black -Ground

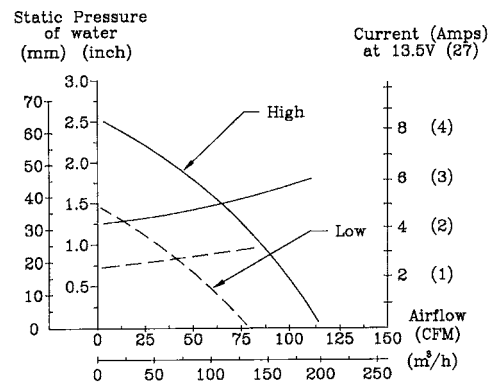
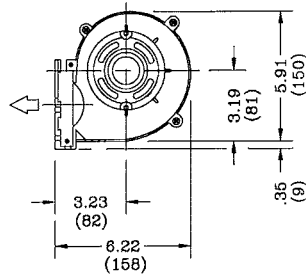
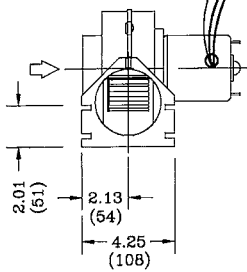

## Part Descriptions: Specifications

Part No.	Description	No.	Part No.	Description
15-0311	Blower 12V	1	25-0033	Blower Housing
15-0312	Blower 24V	2	25-0291	Blower Wheel (C.C.W.)
Blower Housing and Blower Wheel made of ABS plastic.		3	25-0344	Motor 12V
			25-0107	Motor 24V
		4	25-0022	Clip

2-Speed wire wound motor.  
 Weight -2.4 lbs. (1.1 kg)

## Features

The 503 is an excellent defrost booster blower. It can also be used to bring outside air into the cab.

# Blower Model 505

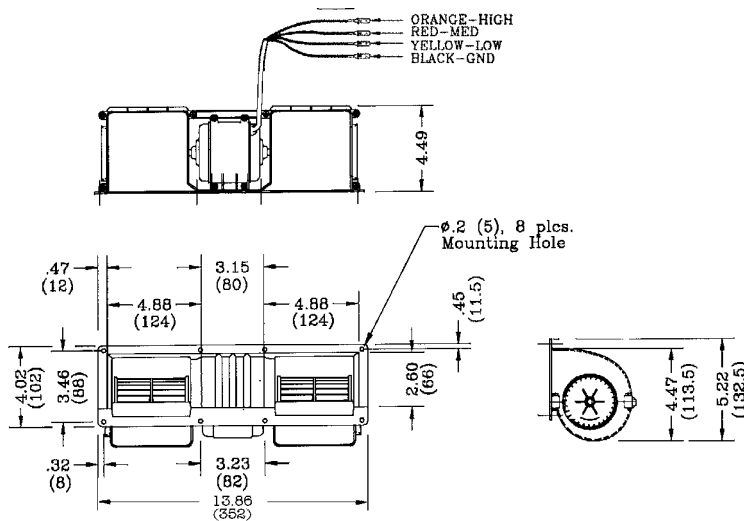
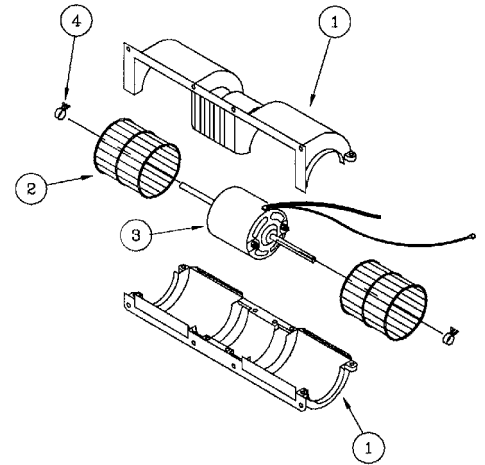
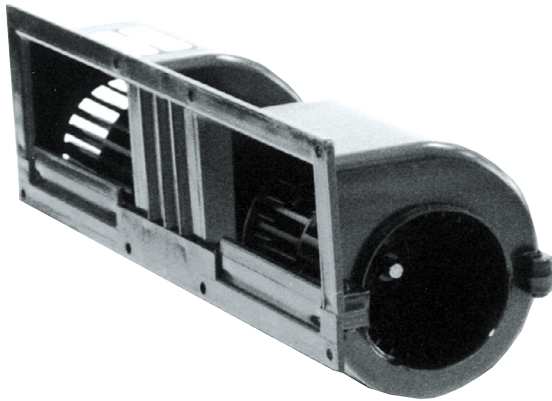

ALL WIRES : 16GA (60°) 300 MM Long  
TERMINALS 4x .25 Tab Terminal Amp # 42460- 2

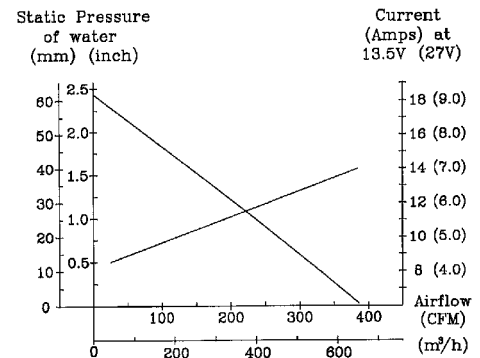

## Part Descriptions: Specifications

Part No.	No.	Part No.	Description
15-0503		Blower 12V	
15-0504		Blower 24V	
	1	25-0017	25-0017
	2	25-0021	25-0021
	3	25-0070	25-0070
		25-0075	25-0075
	4	25-0022	25-0022

### Specifications

Blower Housing and Blower Wheel made of ABS Plastic.

3-Speed wire wound motor.  
Weight -4 lbs. (1.8 kg)

### Features

The 505 is a compact high performance blower which is ideal for extra air flow to the window areas of the cab.

# Blower Model 506

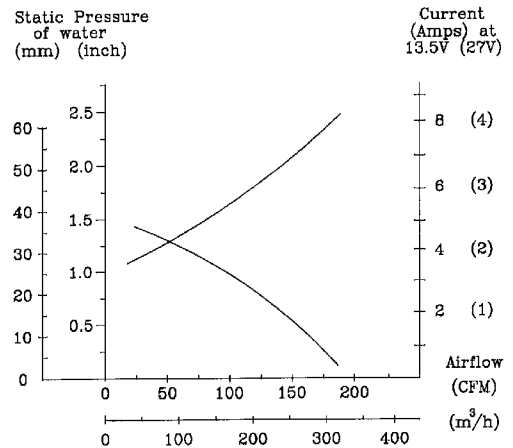
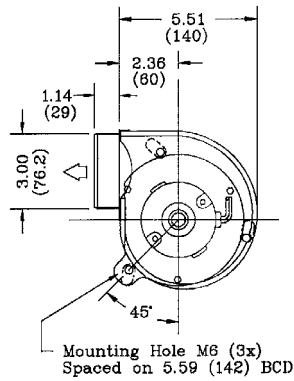
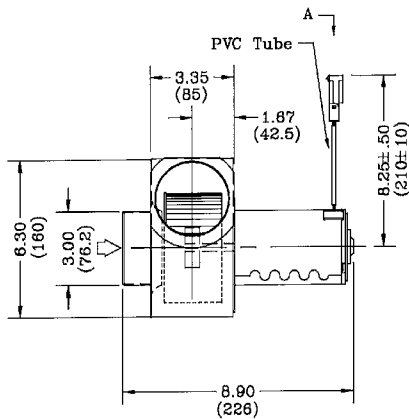
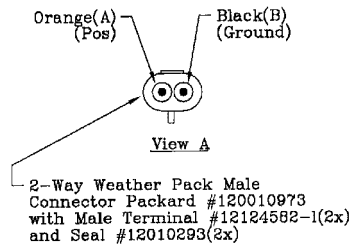
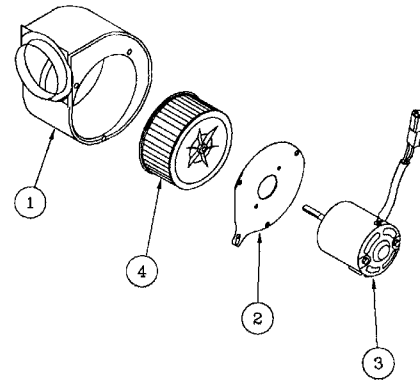
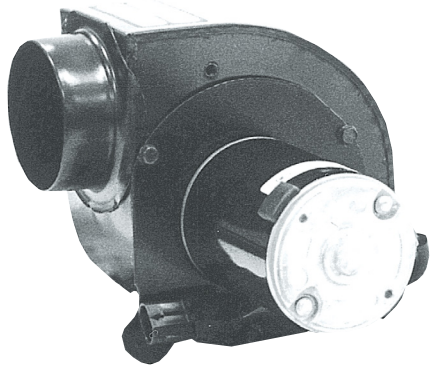

## Part Descriptions: Specifications

Part No.	Description
15-0601	Blower 12V
15-0602	Blower 24V
Blower Housing made of 18/20GA (1.25/1mm) Cold Rolled Steel and finished in semi-gloss epoxy powder coat.	
Sealed Motor has long life brushes and ball bearings.	
Blower Wheel made of Talc filled Polypropylene.	
Inlets and Outlets have hose adapters for a 3" airhose.	
Weight	-5 lbs. (2.3 kg)

No.	Part No.	Description
1	25-0337	Blower Housing
2	25-0338	Blower Plate
3	25-0470	Motor 12V
	25-0490	Motor 24V
4	25-0140	Blower Wheel

## Features

The 506 is MCC's choice for bringing outside air into the cab. The sealed motor has long life brushes and ball bearings.

# Blowers **Model 515** Brushless



Airflow 15-1594

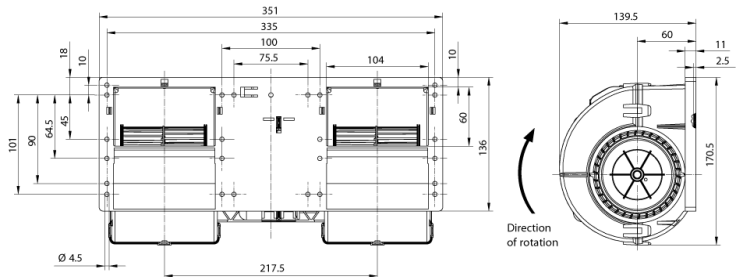

Airflow 15-1579

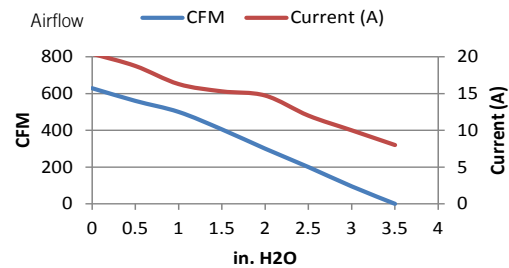
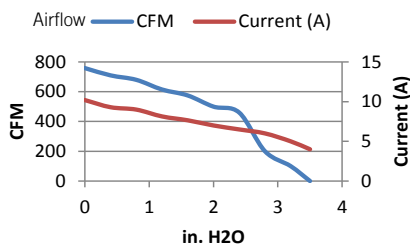

## Part Descriptions: Specifications

Part No.	Voltage	Weight
15-1579	12V	2.00 lbs (0.91kg)
15-1594	24V	4.40 lbs (2.00kg)

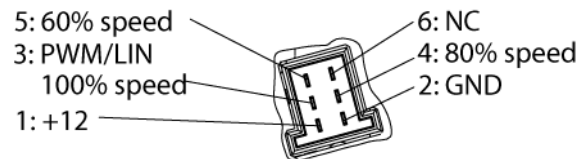

## Features

### AMP Junior Power Timer 6 pole plug

- Designed for HVACs in buses and tractor and trucks
- Long life ball bearing design 40000 hours
- Variable speed control (PWM or linear DC control)
- Locked rotor, over temperature, reverse polarity and under voltage protection
- High efficiency and low noise emission
- Integrated electronics
- IP 24 protection
- free blowing, not recommended for non-stop operation at 85°C

# Blower **Model 515** Brushless

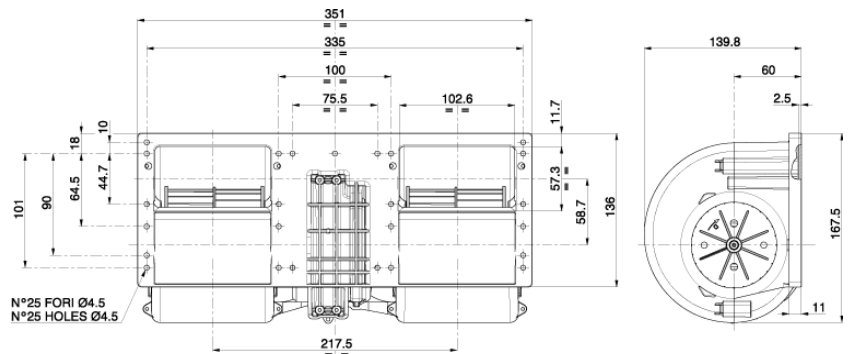

Note: Dimensions in mm only.

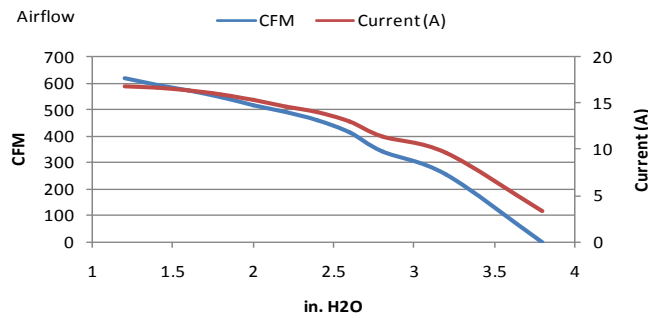

## Part Descriptions: Specifications

**Part No.**

15-15018      Blower 24V

### Features

- Long Life (Brushless motor)
- Waterproof motor (IP 68)
- Maximum current draw: 35 Amps

Attention: This blower must be used with a static pressure higher then 30mm H2O (1.2in H2O).

# Blower **Model 515** Brushless

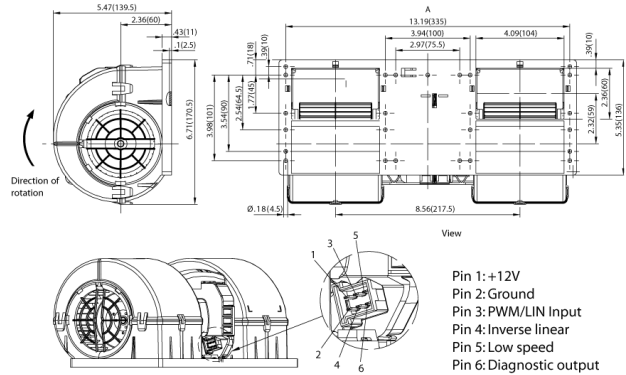

AMP Junior Power Timer 6 pole plug

Note: Dimensions in mm only.

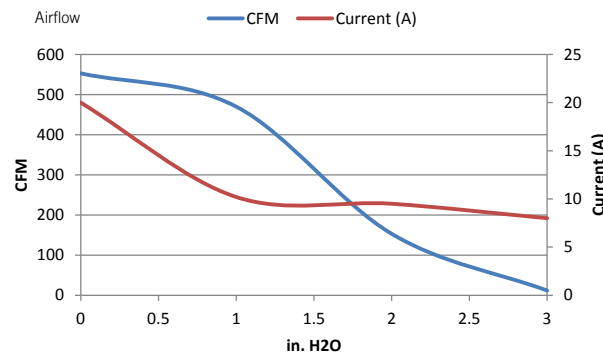

## Part Descriptions: Specifications

**Part No.** \_\_\_\_\_

15-1585 Blower 12V

### Features

- Designed for HVACs in buses and coaches
- Coated motor windings
- Long life ball bearing design 40000 hours
- Locked rotor, over temperature, reverse polarity and under voltage protection
- Variable speed control (PWM or linear DC control)
- Dynamically balanced brushless motor for long life
- free blowing, not recommended for non-stop operation at 85°C

# Blower **Model 515** Brushless

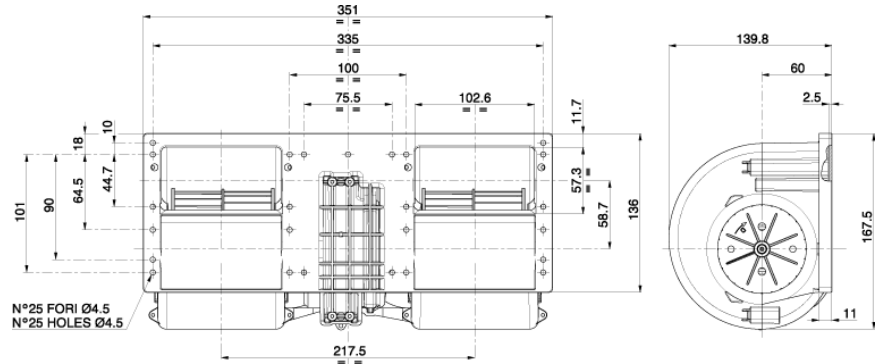

Note: Dimensions in mm only.

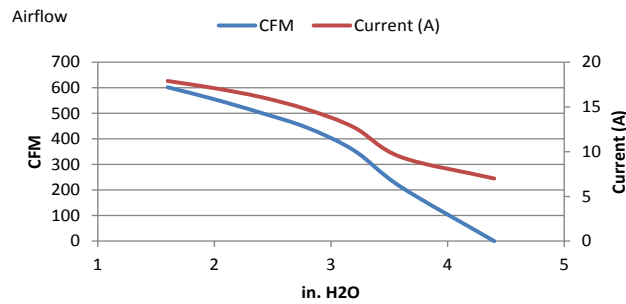

## Part Descriptions: Specifications

**Part No.**

15-15013 Blower 24V

### Features

- Long Life (Brushless motor)
- Waterproof motor (IP 68)
- Maximum current 14A

Attention: This blower must be used with a static pressure higher then 30mm H<sub>2</sub>O (1.2in H<sub>2</sub>O).



# Blowers Model 515

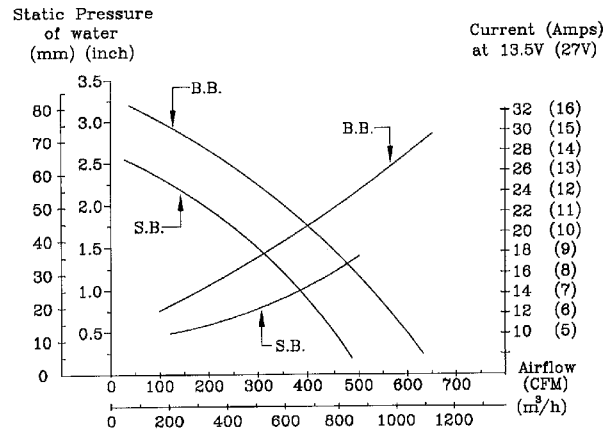
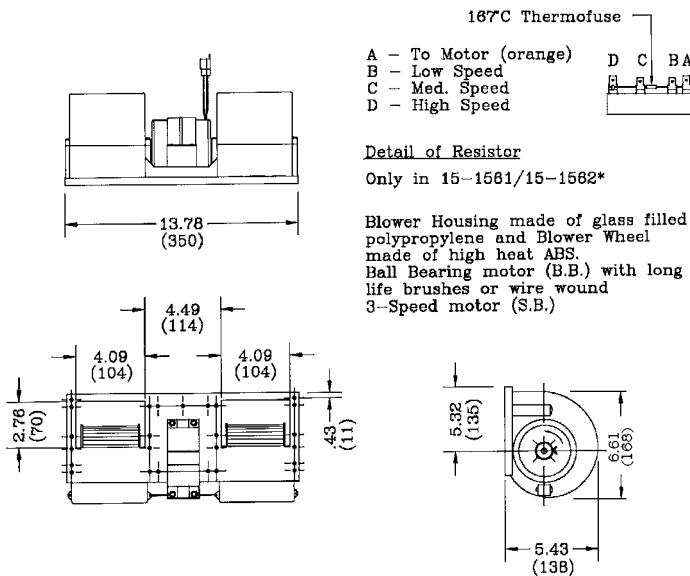
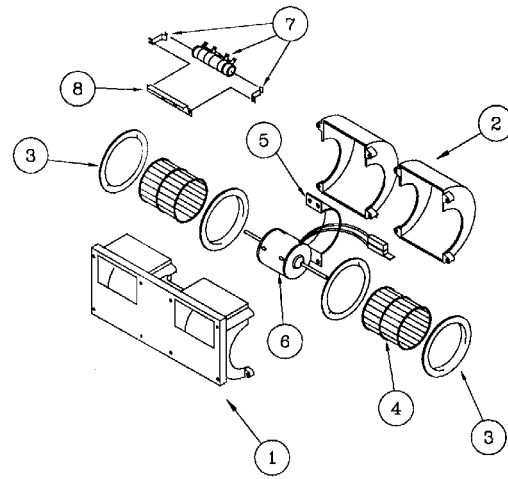
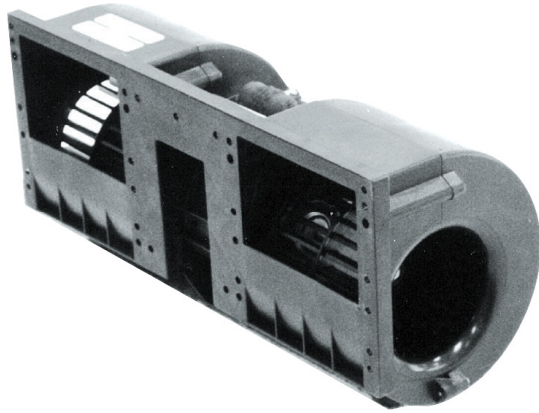

## Part Descriptions: Specifications

Part No.	Description	No.	Part No.	Description	No.	Part No.	Description
15-1501	Blower 12V (1 Sp.)	1	25-0048	Blower Housing	6	25-0053	Motor 12V (3 Sp.)
15-1502	Blower 24V (1 Sp.)	2	25-0348	Blower Housing Top		25-0076	Motor 24V (3 Sp.)
15-1513	Blower 12V (3 Sp.)	3	25-0060	Venturi		25-0645	Motor 12V (B.B.)
15-1514	Blower 24V (3 Sp.)	4	25-0200	Blower Wheel		25-0650	Motor 24V (B.B.)
15-1561	Blower 12V (3 Sp./Resistor)	5	25-0271	Motor Mount		25-0655	Motor 12V (B.B.)
15-1562	Blower 24V (3 Sp./Resistor)					25-0660	Motor 24V (B.B.)
Weight	-4.5 lbs. (2 kg)				7	25-0601	Resistor 12V
						25-0602	Resistor 24V
					8	29-0130	Resistor Bracket

## Features

The 515 is used in the majority of MCC's air conditioning units. It is the right sized package for most off-road blower applications. The glass filled polypropylene design makes the 515 a rugged affordable blower. The blower wheels and motor are balanced as an assembly.

# Blower **Model 519** Brushless

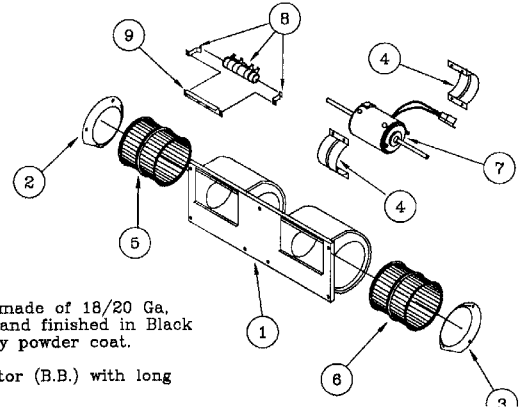
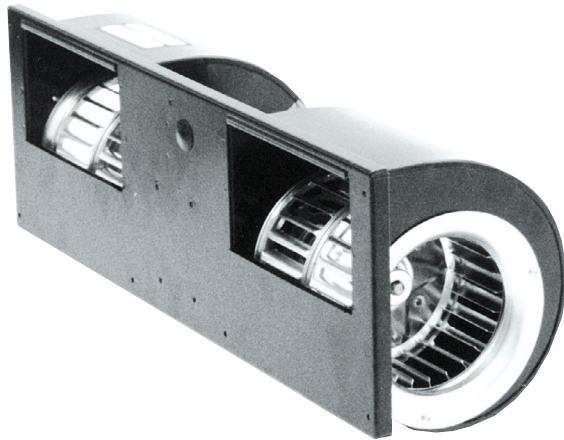

Blower Housing made of 18/20 Ga. (1.25mm/imm) and finished in Black semi-gloss epoxy powder coat.

Ball Bearing motor (B.B.) with long life brushes.

Blower Wheel made of Aluminium.

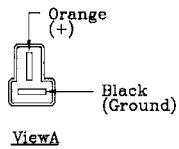
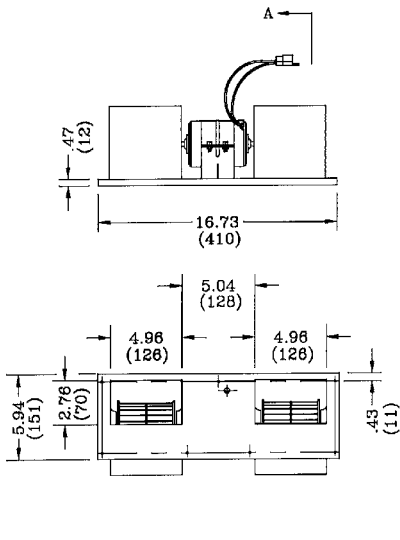

- A - to motor (Orange)
- B - low speed
- C - med. speed
- D - high speed

**Detail of Resistor**  
Only in 15-1961/15-1962\*

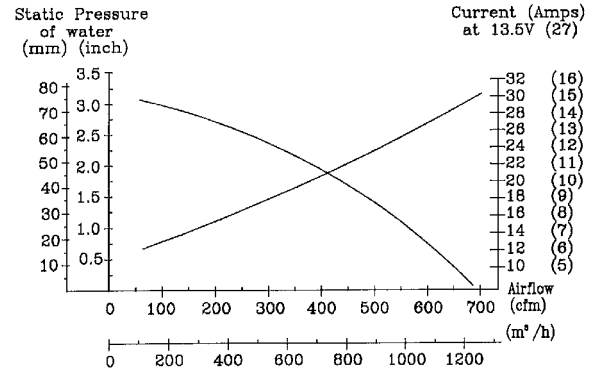

## Part Descriptions: Specifications

Part No.	No.	Part No.	Description	No.	Part No.	Description	
15-1943	Blower 12V	1	25-0240	Blower Housing	6	25-0399	Blower Wheel (C.C.W.)
15-1944	Blower 24V	2	25-0411	Venturi	7	25-0265	Motor 12V
15-1961	Blower 12V (3 Sp.)	3	25-0412	Venturi		25-0270	Motor 24V
15-1962	Blower 24V (3 Sp.)	4	25-0234	Motor Mount	8	25-0601	Resistor 12V
		5	25-0398	Blower Wheel (C.W.)		25-0604	Resistor 24V
Weight	-8.4 lbs. (3.8 kg)				9	29-0130	Resistor Bracket

## Features

The 519 is a high performance blower assembly for high volume blower requirements.

# Blower Model 520 Brushless

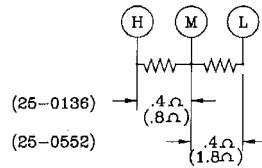
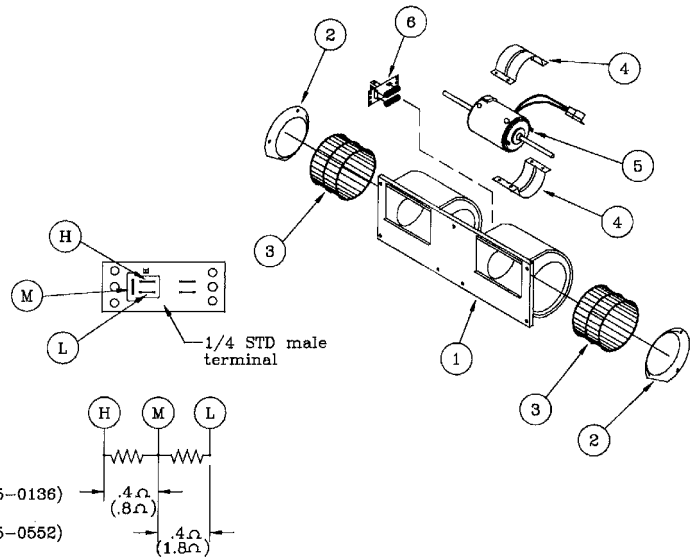
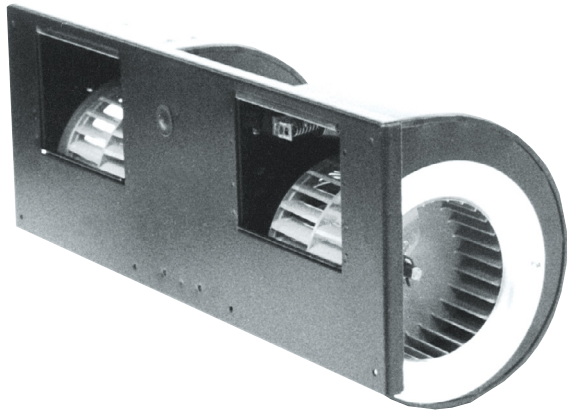

Detail of Resistor

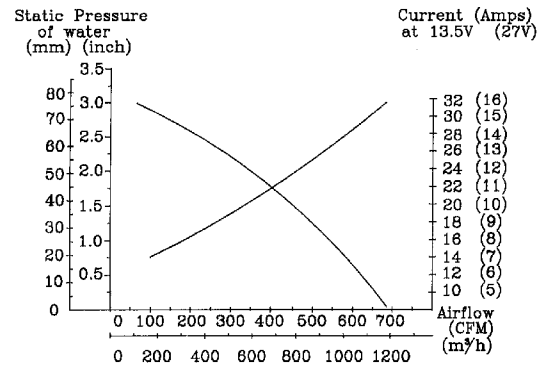
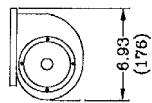
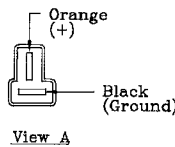
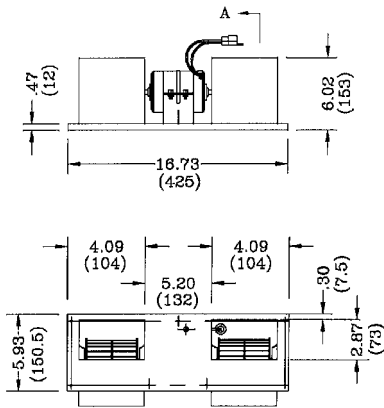

## Part Descriptions: Specifications

Part No.	No.	Part No.	Description
15-2033	1	25-0159	Blower Housing
15-2034	2	25-0164	Venturi
	3	25-0047	Blower Wheel
	4	24-0234	Motor Mount
	5	25-0265	Motor 12V
		25-0270	Motor 24V
	6	25-0136	Resistor 12V
		25-0552	Resistor 24V

Blower Housing made of Cold Rolled Steel finished in black semi-gloss powder coat.  
 Blower Wheels made of high heat ABS.  
 Motor has ball bearings and long life brushes.  
 Blower has resistor for 3-Speed operation.  
 Weight -8.4 lbs. (3.8 kg)

## Features

The 520, like the 519, is a high performance blower. Like all of the MCC blowers, the 520 is designed for years of reliable performance in demanding conditions. The blower wheels and motor are balanced as an assembly.

# Blower Model 530 Brushless

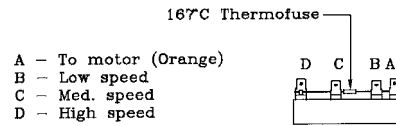
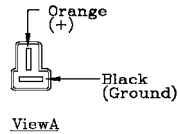
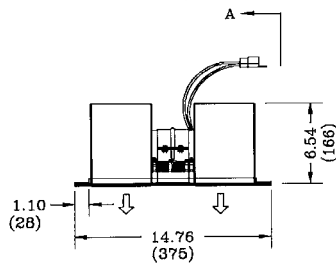
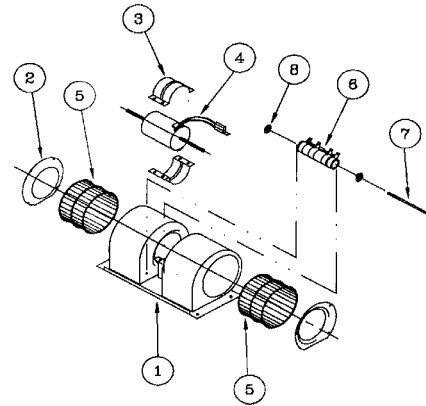
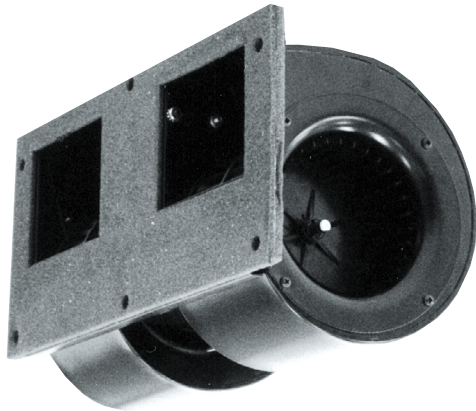

167°C Thermofuse  
 A - To motor (Orange)  
 B - Low speed  
 C - Med. speed  
 D - High speed

Detail of Resistor

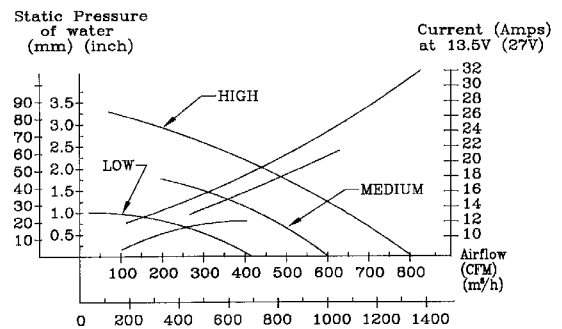
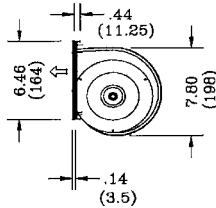
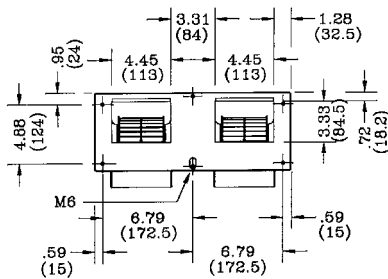

## Part Descriptions: Specifications

Part No.	No.	Part No.	Description
15-3001	1	25-0386	Blower Housing
15-3002	2	25-0387	Venturi
	3	24-0234	Motor Mount
	4	25-0215	Motor 12V
		25-0250	Motor 24V
	5	25-0300	Blower Wheel
	6	25-0601	Resistor 12V
		25-0604	Resistor 24V
	7	29-0233	Through Bolt
	8	29-0234	Centering Washer

Casing made of 18/20GA (1.25/1mm) Cold Rolled Steel finished in black semi-gloss epoxy powder coat.  
 Blower Wheels made of glass filled black nylon.  
 Blower has resistor for 3-Speed operation.  
 Permanent magnet motor has ball bearings and long-life brushes.  
 Weight -9.2 lbs. (4.2 kg) t

### Features

The 530 is one of MCC's largest capacity blower assemblies. Often used in the toughest air flow requirements involving high static pressure.

# Blower **Model 530** Brushless

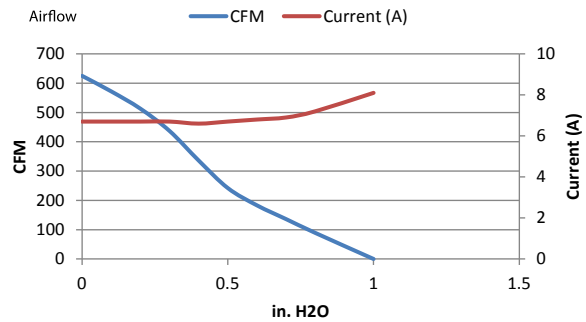
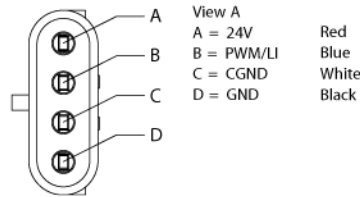
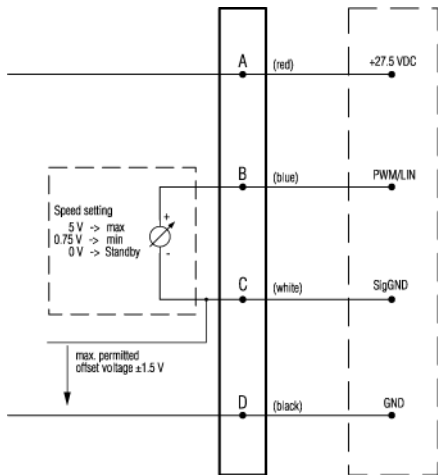
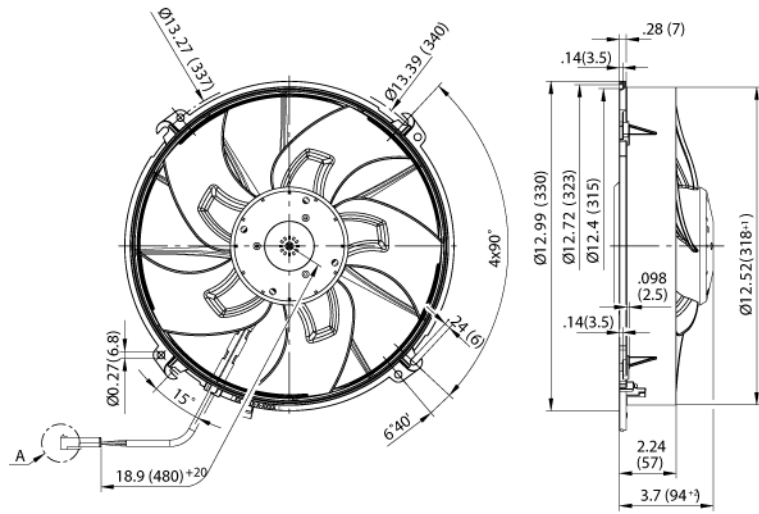

## Part Descriptions: Specifications

### Part No.

25-3089 Blower 24V

### Features

- Long life ball bearing brushless motor
- Conformally coated electronics with one way ventilation air port
- Variable speed control (PWM or linear DC control)
- Heavy duty construction
- Free blowing not recommended

# Blower **Model 561** Brushed

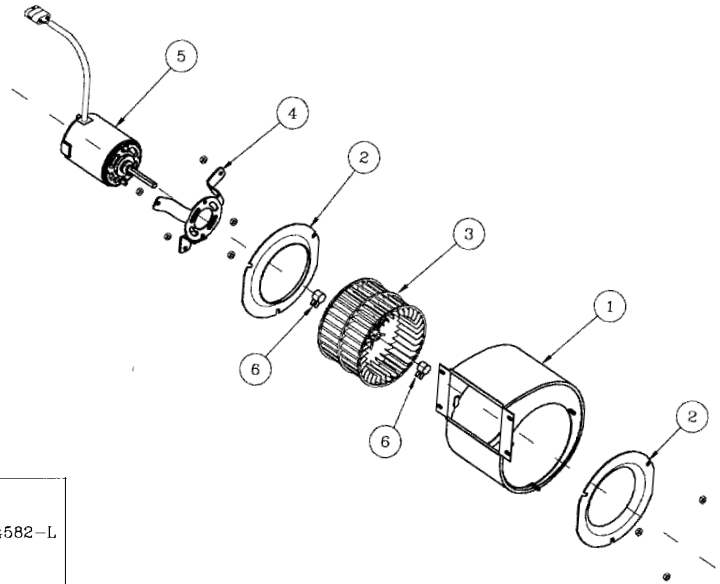

CONNECTOR PACKARD  
 MALE (WP) #12010973  
 MCC #31-1068  
 TERMINAL MALE #12124582-L  
 MCC #31-1039 (2X)  
 SEAL #121010293  
 MCC #31-1024 (2X)  
 EXT. 200±10

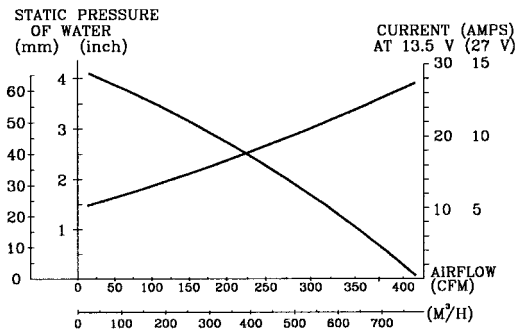
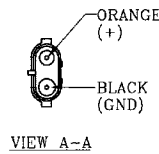
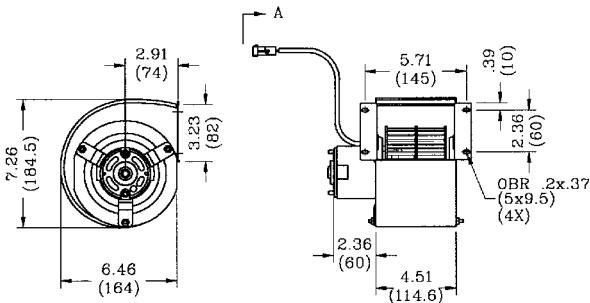

## Part Descriptions: Specifications

Part No.	No.	Part No.	Description
15-6101	1	25-0760	Blower Housing
15-6102	2	25-0762	Venturi
	3	25-0300	Blower Wheel
	4	25-0790	Motor Bracket
	5	25-0806	Motor 24V
		25-0805	Motor 12V
	6	25-0022	Clip

Blower Housing made of 18 & 22 ga (1.25 and .75 mm) cold rolled steel, finished in black semi-gloss powder coat. Blower Wheels made of glass filled black nylon.

Weight -5.5 lbs. (2.5 kg)

## Features

The 561 is a high performance single squirrel cage blower assembly. It is designed to move air to specific areas in high volume.

# Blower Model 575

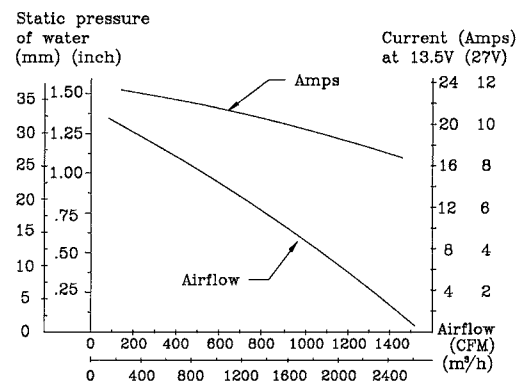
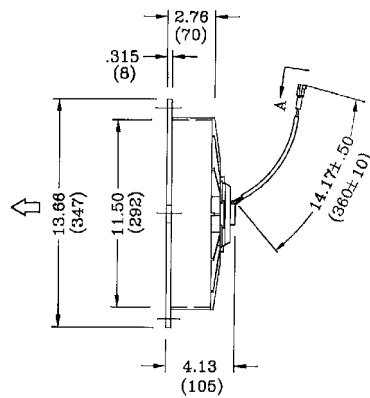
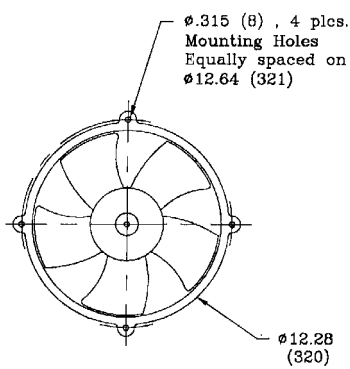
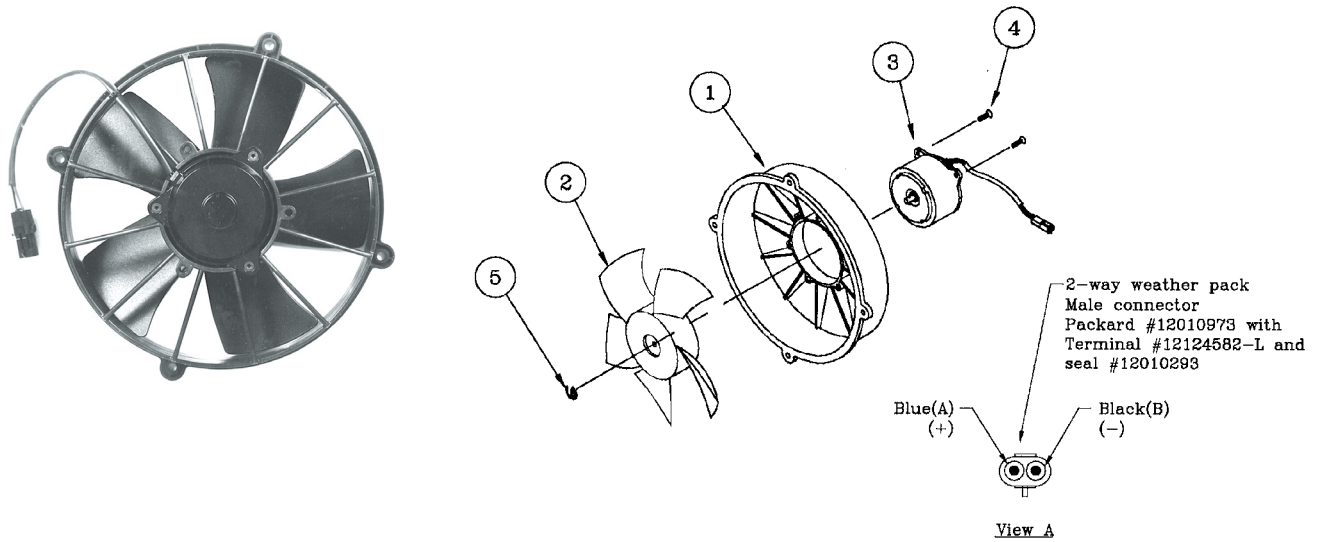

## Part Descriptions: Specifications

Part No.	No.	Part No.	Description
15-7501	1	25-0577	Venturi
15-7502	2	25-0579	Fan
	3	25-0591	Motor 12V
		25-0592	Motor 24V
	4	29-0166	Screw
	5	29-0167	"C" Clip

Venture made of 30% G.F. polypropylene and fan made of 30% G.F. nylon.

Weight -5.2 lbs. (2.4 kg)

## Features

The 575 is designed to deliver maximum performance using a single fan assembly. The durable 30% glass filled nylon construction ensures long life.

# Blower **Model 577** Brushed

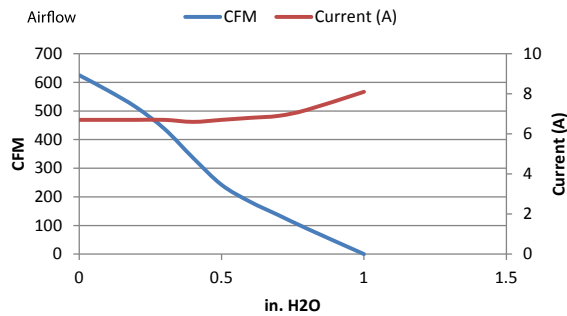
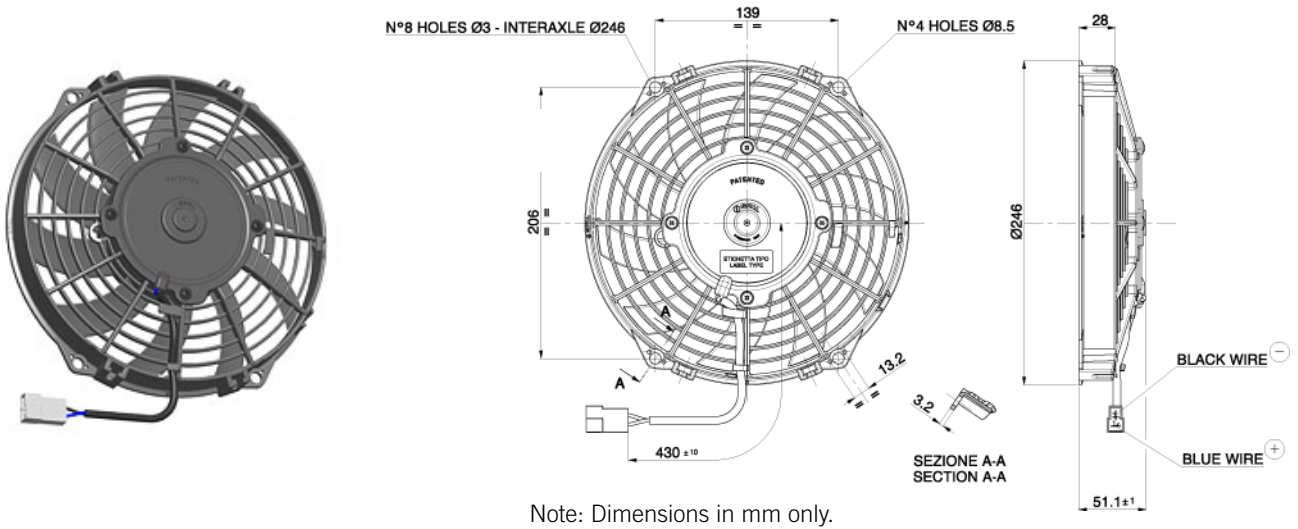

## Part Descriptions: Specifications

**Part No.** \_\_\_\_\_  
 15-7705 Blower 12V

### Features

- Long Life
- Low Noise
- Waterproof motor (IP 68)



# Blower **Model 579** Brushed

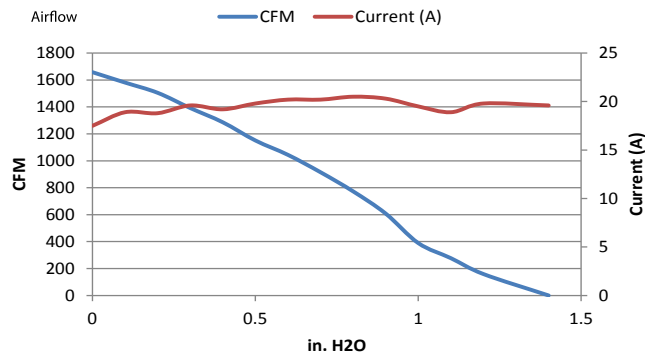
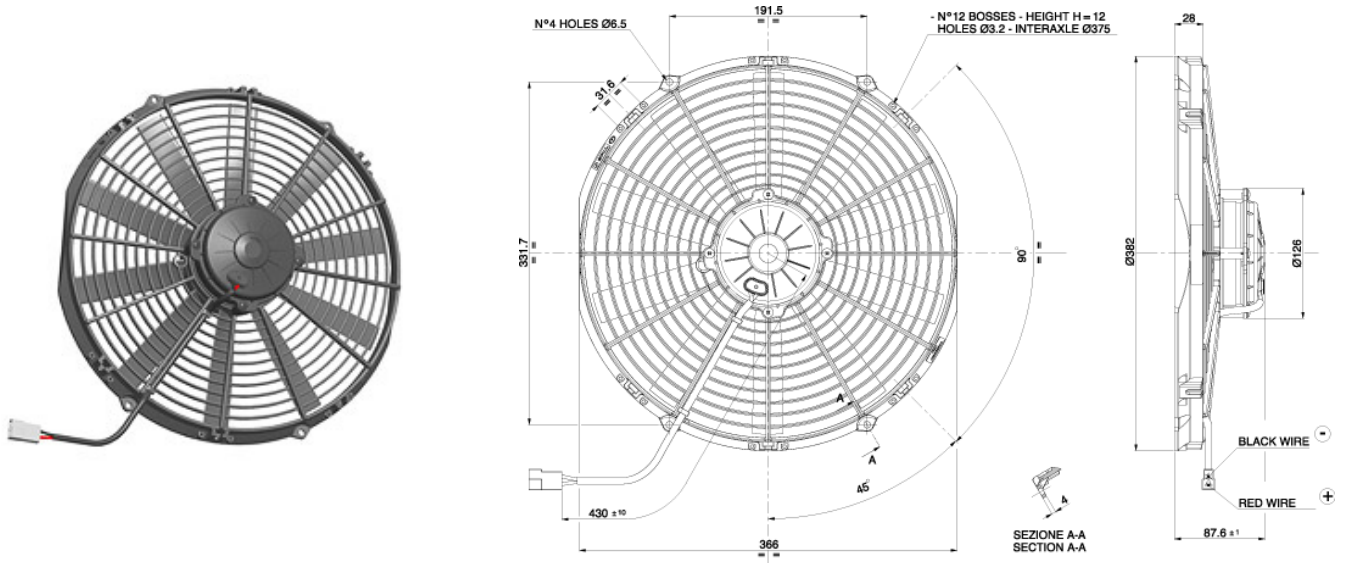

## Part Descriptions: Specifications

**Part No.** \_\_\_\_\_  
 15-7908 Blower 24V

### Features

- Long Life
- Waterproof motor (IP 68)

# Blower Model 582

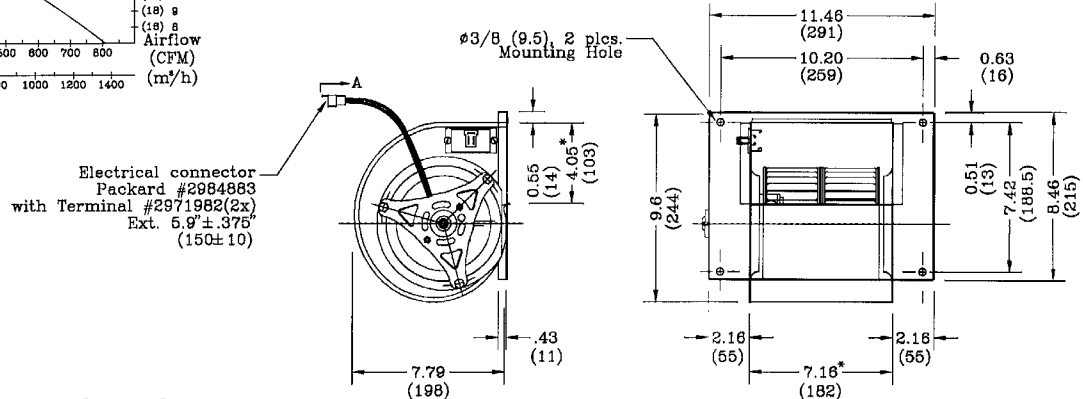
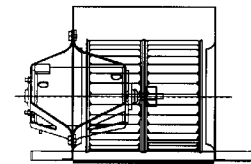
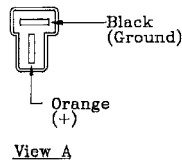
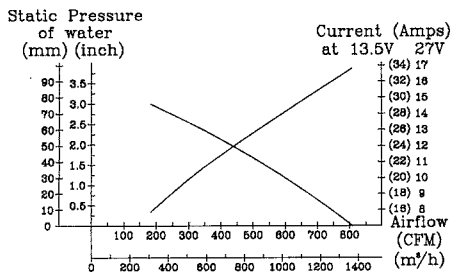
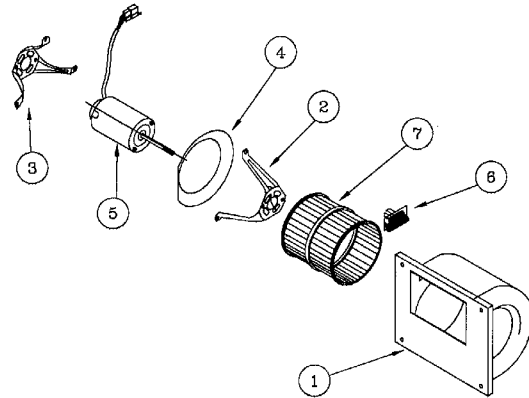
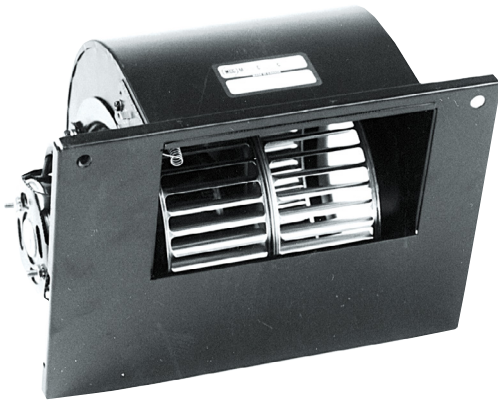

## Part Descriptions: Specifications

Part No.	No.	Part No.	Description
15-8201	1	25-0317	Blower 12V
15-8202	2	25-0320	Blower 24V
	3	25-0319	Blower Housing
	4	25-0318	Motor Mount
	5	25-0150	Venturi
	6	25-0136	Motor 12V
	7	25-0552	Motor 24V
		25-0155	Resistor 12V
			Resistor 24V
			Blower Wheel

Blower housing made of 18/20GA (1.25/1mm) Cold Rolled Steel and finished in black semi-gloss epoxy powder coat.  
Motor has long life brushes and ball bearings.  
Blower Wheel made of aluminum.  
\* Outlet dimensions.  
Weight -8.8 lbs. (4 kg)

## Features

The 582 is one of MCC's largest capacity blower assemblies. Originally designed for MCC's mass transit division, the 582 is fast becoming a popular off-road blower.



## **Notes**